

## FEATURES

- ◆RoHS compliant
- ◆I/O isolation voltage 1000VDC
- ◆Operating Temperature: -40°C ~ +85°C
- ◆High efficiency up to 81%
- ◆Fully encapsulated toroidal magnetics
- ◆Internal SMD construction
- ◆Power density up to 0.85W/cm<sup>3</sup>
- ◆No electrolytic or tantalum capacitors
- ◆5V, 12V and 15V output
- ◆No heatsink required
- ◆Dual output from a single input rail
- ◆UL 94V-0 package material
- ◆No external components required
- ◆Industry standard pinout
- ◆Power sharing on output
- ◆MTTF up to 3.4 million hours

## MODEL SELECTION

B<sup>①</sup>05<sup>②</sup>05<sup>③</sup>X<sup>④</sup>LS(D)<sup>⑤</sup>

- ① Product Series
- ② Input Voltage
- ③ Output Voltage
- ④ Fixed Input
- ⑤ Package Style

## APPLICATIONS

The B-XLS(D) series of industrial temperature range DC/DC converters are the standard building blocks for on-board distributed power systems. They are ideally suited for providing single rail supplies on primarily digital boards with the added benefit of galvanic isolation to reduce switching noise. Surface mount technology and advanced packaging materials produce rugged reliable performance over an extended temperature range from -40°C to 85°C.



## SELECTION GUIDE

Order code	Input Voltage (V)	Output Voltage (V)	Output Current (mA)	Input Current (Rated Load) (mA)	Efficiency (%)	Isolation Capacitance (PF)	MTTF <sup>1</sup> (KHRS)
B0303XLS	3.3	3.3	303	420	72	26	1987
B0305XLS	3.3	5	200	409	74	26	1979
B0505XLS	5	5	200	290	69	28	1847
B0505XLD	5	5	200	290	69	28	1847
B0512XLS	5	12	83	260	77	33	981
B0512XLD	5	12	83	260	77	33	981
B0515XLS	5	15	67	253	79	40	667
B0515XLD	5	15	67	253	79	40	667
B1205XLS	12	5	200	121	69	36	1485
B1205XLD	12	5	200	121	69	36	1485
B1212XLS	12	12	83	110	76	58	869
B1212XLD	12	12	83	110	76	58	869
B1215XLS	12	15	67	110	76	56	613
B1215XLD	12	15	67	110	76	56	613
B1505XLS	15	5	200	93	69	27	2110
B1505XLD	15	5	200	93	69	27	2110
B1512XLS	15	12	83	85	77	58	1790
B1512XLD	15	12	83	85	77	58	1790
B1515XLS	15	15	67	84	78	67	1560
B1515XLD	15	15	67	84	78	67	1560
B2405XLS	24	5	200	60	70	61	1253
B2405XLD	24	5	200	60	70	61	1253
B2412XLS	24	12	83	53	78	98	784
B2412XLD	24	12	83	53	78	98	784
B2415XLS	24	15	67	52	80	122	566
B2415XLD	24	15	67	52	80	122	566

## Input Characteristics

Parameter	Conditions	Min	Typ	Max.	Units
Voltage range	Continuous operation, 5V input types	4.5	5	5.5	V
	Continuous operation, 12V input types	10.8	12	13.2	
	Continuous operation, 15V input types	13.5	15	16.5	
	Continuous operation, 24V input types	21.6	24	26.4	
Reflected ripple current	5V&12V input types		1.6	2.0	mA p-p
	15V&24V input types		5	10.0	

## Absolute Maximum Ratings

Lead temperature 1.5mm from case for 10 seconds	300°C
Internal power dissipation	550mW
Input voltage VIN, B0505XLS, B0512XLS, B0515XLS types	7V
Input voltage VIN, B1205XLS, B1212XLS, B1215XLS types	15V
Input voltage VIN, B1505XLS, B1512XLS, B1515XLS types	18V
Input voltage VIN, B2405XLS, B2412XLS, B2415XLS types	28V

1. Calculated using MIL-HDBK-217FN2 calculation model with nominal input voltage at full load.

**OUTPUT CHARACTERISTICS**

Parameter	Conditions	Min.	Typ.	Max.	Units
Rated Power	TA=-40°C to 120°C			1	W
Voltage Set Point Accuracy	See tolerance envelope				
Line regulation	High VIN to low VIN		1.0	1.2	%%

**Isolation Characteristics**

Parameter	Conditions	Min.	Typ.	Max.	Units
Isolation test voltage	Flash tested for 1 second	1000			VDC
Resistance	Viso= 1000VDC	10			GΩ

**General Characteristics**

Parameter	Conditions	Min.	Typ.	Max.	Units
Switching frequency	5V input types		110		kHz
	12V input types		160		
	15V input types		90		
	24V input types		80		

**Temperature Characteristics**

Parameter	Conditions	Min.	Typ.	Max.	Units
Specification	All output types	-40		85	°C
Storage		-50		130	
Case temperature above ambient	5V output types		23		
	All other output types		28		

**TOLERANCE ENVELOPE**

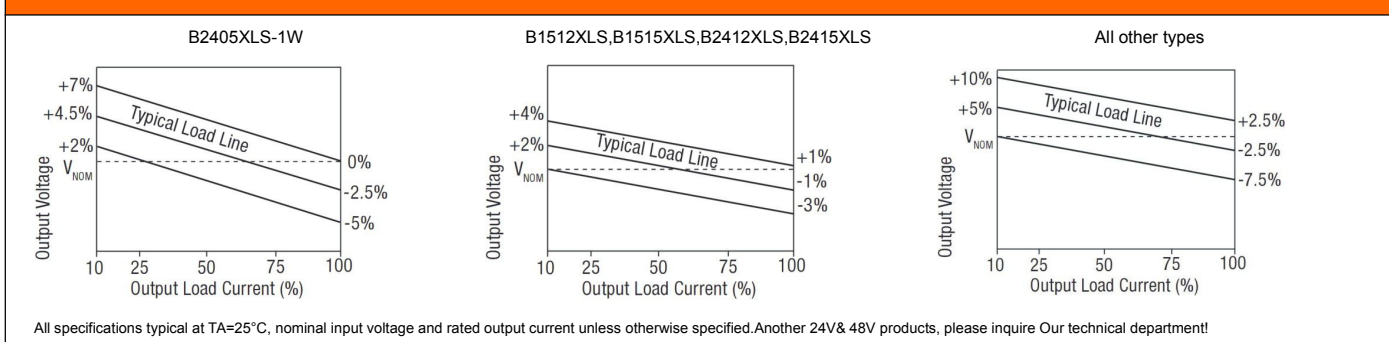

### Technical notes

#### ISOLATION VOLTAGE

"Hi Pot Test", "Flash Tested", "Withstand Voltage", "Dielectric Withstand Voltage" & " Isolation Test Voltage" are all terms that relate to the same thing, a test voltage. Applied for a specified time, across a component designed to provide electrical isolation, to verify the integrity of that isolation. Professional Power Module B\_XLS series of DC/DC converters are all 100% production tested at their stated isolation voltage. This is 1KVDC for 1 second.

A question commonly asked is, "What is the continuous voltage that can be applied across the part in normal operation?"

For a part holding no specific agency approvals, such as the B\_XLS series ,both input and output should normally be maintained within SELV limits i.e. less than 42.4V peak, or 60VDC. The isolation test voltage represents a measure of immunity to transient voltages and the part should never be used as an element of a safety isolation system. The part could be expected to withstand several times the stated test voltage, the isolation capability does depend on the wire insulation. Any material, including this enamel (typically polyurethane) is susceptible to eventual chemical degradation when subject to very high applied voltages thus implying that the number of tests should be strictly limited. We therefore strongly advise against repeated high voltage isolation testing, but if it is absolutely required, that the voltage be reduced by 20% from specified test voltage.

#### REPEATED HIGH-VOLTAGE ISOLATION TESTING

It is well known that repeated high-voltage isolation testing of a barrier component can actually degrade isolation capability, to a lesser or greater degree depending on materials. Construction and environment. The B\_XLS series has toroidal isolation transformers, with no additional insulation between primary and secondary windings of enameled wire. While parts can be expected to withstand several times the stated test voltage, the isolation capability does depend on the wire insulation. Any material, including this enamel (typically polyurethane) is susceptible to eventual chemical degradation when subject to very high applied voltages thus implying that the number of tests should be strictly limited. We therefore strongly advise against repeated high voltage isolation testing, but if it is absolutely required, that the voltage be reduced by 20% from specified test voltage.

This consideration equally applies to agency recognized parts for better than functional isolation where the wire enamel insulation is always supplemented by a further insulation system of physical spacing or barriers.

### OUTPUT RIPPLE REDUCTION

#### Output ripple reduction

By using the values of inductance and capacitance stated, the output ripple at the rated load is lowered to 5mV p-p max.

#### Component selection

Capacitor: Ceramic chip capacitors are recommended. It is required that the ESR(Equivalent Series Resistance) should be as low as possible. X7R types are recommended. The voltage rating should be at least twice(except for 15V output), the rated output voltage of the DC/DC converter.

Inductor: The rated current of the inductor should not be less than of the output of the DC/DC converter. At the rated current, the DC resistance of the inductor should be such that the voltage drop across the inductor is <2% of the rated voltage of the DC/DC converter. The SRF(Self Resonant Frequency) should be >20MHz.

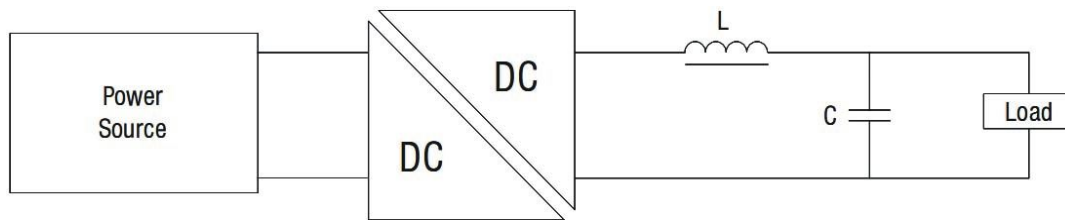

### CHARACTERISATION TEST METHODS

#### Ripple & Noise Characterization Method

Ripple and noise measurements are performed with the following test configuration.

C1	1 $\mu$ F X7R multilayer ceramic capacitor, voltage rating to be a minimum of 3 times the output voltage of the DC/DC converter
C2	10 $\mu$ F tantalum capacitor, voltage rating to be a minimum of 1.5 times the output voltage of the DC/DC converter with an ESR of less than 100m $\Omega$ at 100 KHz
C3	100nF multilayer ceramic capacitor, general purpose
R1	450 $\Omega$ resistor, carbon film, $\pm$ 1% tolerance
R2	50 $\Omega$ BNC termination
T1	3T of the coax cable through a ferrite toroid
RLOAD	Resistive load to the maximum power rating of the DC/DC converter. Connections should be made via twisted wires

Measured values are multiplied by 10 to obtain the specified values.

#### Differential Mode Noise Test Schematic

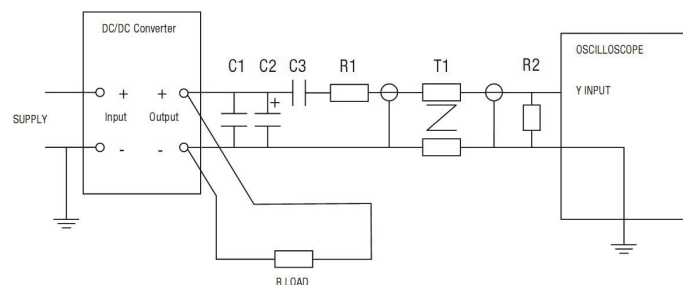

### PACKAGE SPECIFICATIONS

MECHANICAL DIMENSIONS	
7 Pin SIP package	14 Pin DIP package
<p>0.77 (19.50) 0.236 (6.00) 0.394 (10.00) MICRODC 0.022 (0.55) 0.0178 (0.45) 0.181 (4.60) 0.141 (3.60) 0.074±0.02 (1.88±0.50) 0.0118 (0.30) 0.0079 (0.20) 0.05 (1.25) 0.1 (2.54)</p>	<p>20.00 [0.787] 10.00 [0.394] 0.50 [0.020] (Side View) 7.00 [0.276] 4.10 [0.161] 17.78 [0.700] 15.24 [0.600] 1.00 [0.039] (Bottom View) 7.62 [0.300] 14 11 9 8 0.30 [0.012] 0.50 [0.020] 2.54 [0.100]</p>
<p>All dimensions in inches <math>\pm 0.01</math> (mm <math>\pm 0.25</math>mm). All pins on a 0.1 (2.54) pitch and within <math>\pm 0.01</math> (0.25) of true position.</p>	

FOOTPRINT DETAILS			
-7 PIN SIP		-14 PIN DIP	
Pin	Function	Pin	Function
1	+Vin	1	-Vin
2	-Vin	7	NC
4	-Vout	8	-Vout
6	+Vout	9	+Vout
		11	No Pin
		14	+Vin

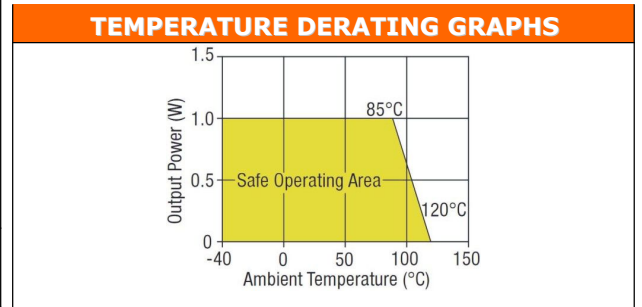

### RECOMMENDED FOOTPRINT DETAILS

#### 7 Pin SIP Package

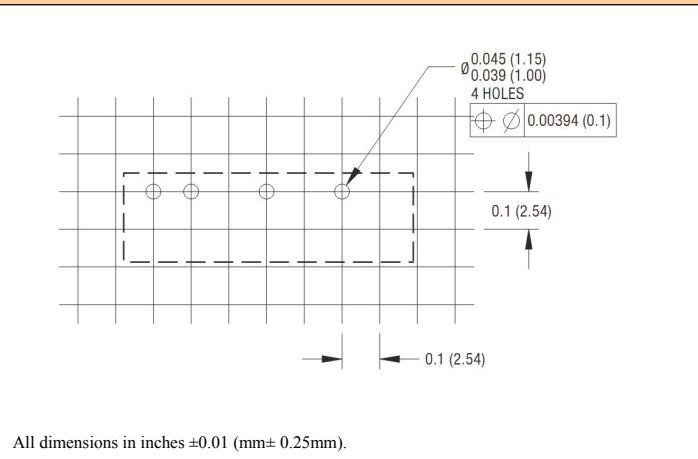

All dimensions in inches  $\pm 0.01$  (mm  $\pm 0.25$ mm).

### RECOMMENDED FOOTPRINT DETAILS

#### 14 Pin SIP Package

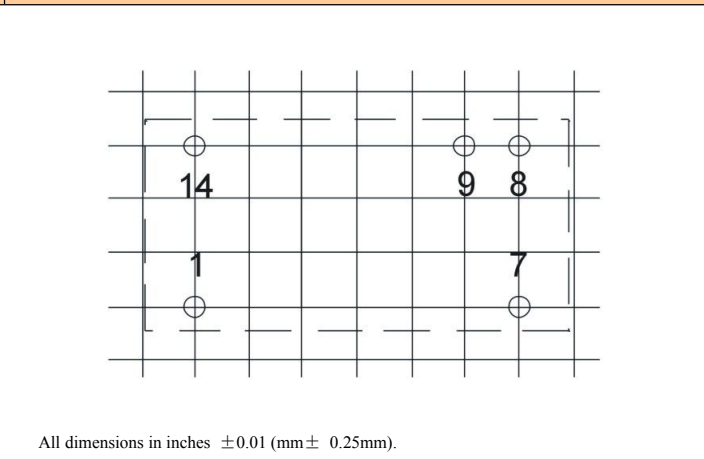

All dimensions in inches  $\pm 0.01$  (mm  $\pm 0.25$ mm).

### TUBE OUTLINE DIMENSIONS

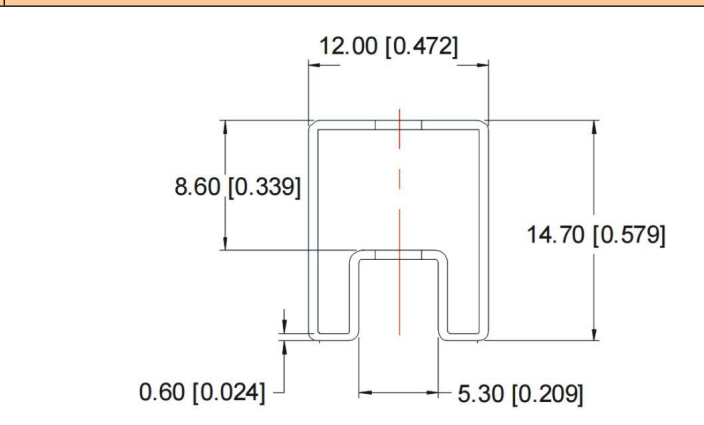
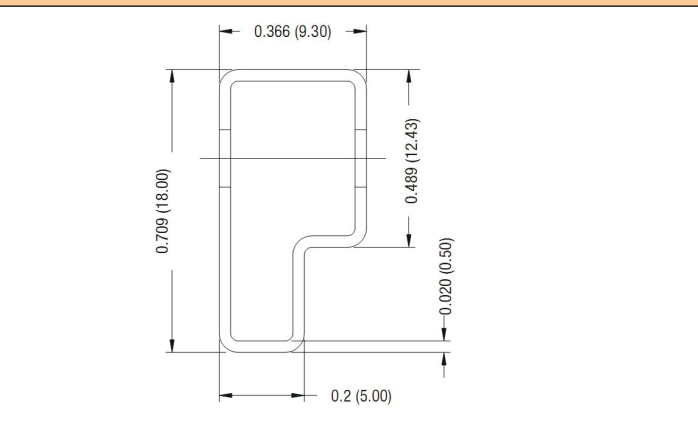

Unless otherwise stated all dimensions in inches (mm)  $\pm 0.5$ mm.

Tube length (14 Pin DIP) : 20.47 (520mm  $\pm 2$ mm).

Tube length (7 Pin SIP) : 20.47 (520mm  $\pm 2$ mm).

Tube Quantity :25